

Half Round Trim & Ex. Jambs

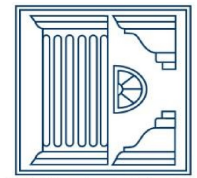

ELIPTICON
Wood Products, Inc.
100% Employee Owned

600 Moasis Drive
Little Chute, WI 54140
Phone: 920/788-9322
Fax: 920/788-3086
www.elipticon.com

Date _____ Job Name _____

Co. Name _____ Contact _____

Phone _____ Fax _____

Quote Purchase Order _____

Fill in: A & B dimensions. A – base dimension, B – height of window.

Standard reveal 1/4" on all casings unless specified.

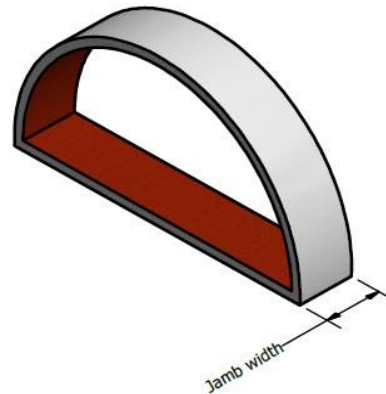
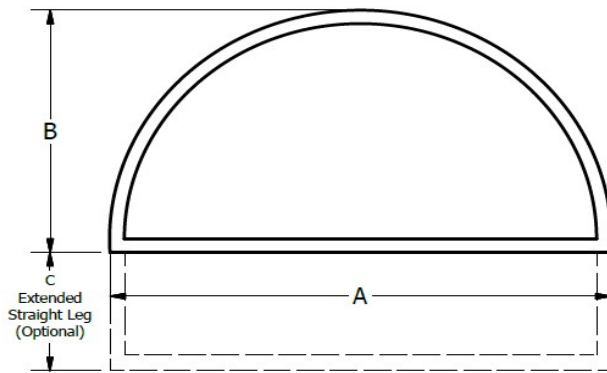

Dimension reference (check one)

- Outside to outside
Jamb thickness _____
- Inside, jamb to jamb

A Dimension: _____

B Dimension: _____

C Extended leg length: _____
(additional charge)

Casing

Profile _____

Wood Species _____

Quantity _____

Extension Jamb

Thickness _____

Width _____

Quantity _____

Rosettes needed. Description _____

Straight moldings needed: length _____ quantity _____

length _____ quantity _____

length _____ quantity _____

Other notes: _____
